

Product Summary

$V_{(BR)DSS}$	$R_{DS(on)TYP}$	I_D
100V	3.3m Ω @10V	150A

Feature

- Split Gate Trench Technology
- Low $R_{DS(ON)}$
- Low Gate Charge
- Low Gate Resistance
- 100% UIS Tested

Application

- Power Management Switches
- Battery Management
- DC/DC Converter
- Motor Driving

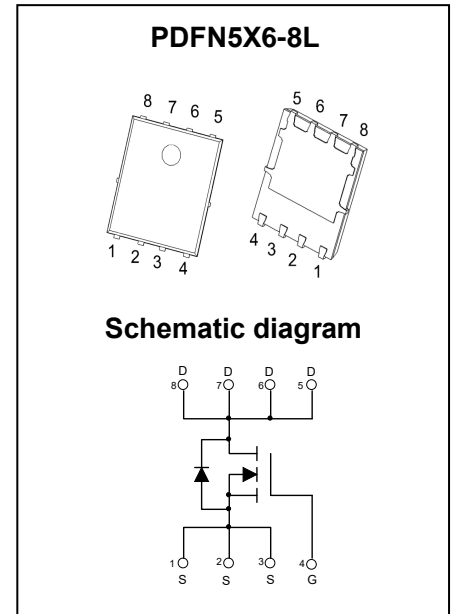

Package Marking and Ordering Information

Part Number	Package	Marking	Packing	Reel Size	Tape Width	Qty
GPT036N10NNC	PDFN5X6-8L	T036N10N	Reel & Tape	330mm	12mm	5000pcs

ABSOLUTE MAXIMUM RATINGS ($T_A = 25^\circ\text{C}$ unless otherwise noted)

Parameter	Symbol	Value	Unit
Drain-Source Voltage	V_{DS}	100	V
Gate-Source Voltage	V_{GS}	± 20	V
Continuous Drain Current ¹	I_D	$T_C = 25^\circ\text{C}$	150
		$T_C = 100^\circ\text{C}$	93
Pulsed Drain Current ²	I_{DM}	600	A
Single Pulsed Avalanche Current ³	I_{AS}	55	A
Single Pulsed Avalanche Energy ³	E_{AS}	755	mJ
Power Dissipation ⁵	P_D	178	W
Thermal Resistance from Junction to Ambient ⁶	$R_{\theta JA}$	50	$^\circ\text{C}/\text{W}$
Thermal Resistance from Junction to Case	$R_{\theta JC}$	0.7	$^\circ\text{C}/\text{W}$
Operating Junction and Storage Temperature Range	T_J, T_{STG}	-55~ +175	$^\circ\text{C}$

MOSFET ELECTRICAL CHARACTERISTICS (T_A = 25°C unless otherwise noted)

Parameter	Symbol	Test Condition	Min	Type	Max	Unit
Off Characteristics						
Drain-Source Breakdown Voltage	V _{(BR)DSS}	V _{GS} = 0V, I _D = 250μA	100			V
Zero Gate Voltage Drain Current	I _{DSS}	V _{DS} = 100V, V _{GS} = 0V			1	μA
Gate-Body Leakage Current	I _{GSS}	V _{GS} = ±20V, V _{DS} = 0V			±100	nA
On Characteristics⁴						
Gate Threshold Voltage	V _{GS(th)}	V _{DS} = V _{GS} , I _D = 250μA	2	3	4	V
Drain-Source On-Resistance	R _{DS(on)}	V _{GS} = 10V, I _D = 30A		3.3	3.9	mΩ
Dynamic Characteristics						
Input Capacitance	C _{iss}	V _{DS} = 50V, V _{GS} = 0V, f = 0.1MHz		5583		pF
Output Capacitance	C _{oss}			990		
Reverse Transfer Capacitance	C _{rss}			33		
Gate Resistance	R _g	V _{DS} = 0V, V _{GS} = 0V, f = 1MHz		2.2		Ω
Switching Characteristics						
Total Gate Charge	Q _g	V _{DS} = 50V, V _{GS} = 10V, I _D = 20A		88		nC
Gate-Source Charge	Q _{gs}			23		
Gate-Drain Charge	Q _{gd}			22		
Turn-On Delay Time	t _{d(on)}	V _{DD} = 50V, V _{GS} = 10V, R _G = 2.5Ω, I _D = 20A		27		ns
Turn-On Rise Time	t _r			36		
Turn-Off Delay Time	t _{d(off)}			58		
Turn-Off Fall Time	t _f			26		
Source-Drain Diode Characteristics						
Diode Forward Voltage ⁴	V _{SD}	V _{GS} = 0V, I _S = 30A			1.2	V

Notes :

- 1.The maximum current rating is limited by package.And device mounted on a large heatsink
- 2.Pulse Test : Pulse Width ≤ 10μs, duty cycle ≤ 1%.
- 3.E_{AS} condition: V_{DD} = 50V, V_{GS} = 10V, L = 0.5mH, R_G = 25Ω Starting T_J = 25°C.
- 4.Pulse Test : Pulse Width ≤ 300μs, duty cycle ≤ 2%.
- 5.The power dissipation P_D is limited by T_{J(MAX)} = 150°C.And device mounted on a large heatsink
- 6.Device mounted on 1in² FR-4 board with 2oz. Copper, in a still air environment with T_A =25°C.

Typical Characteristics

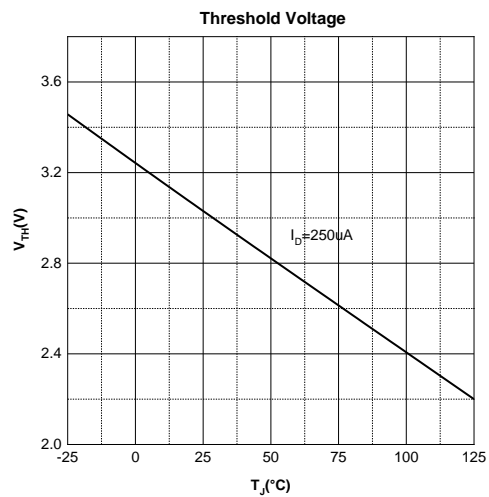
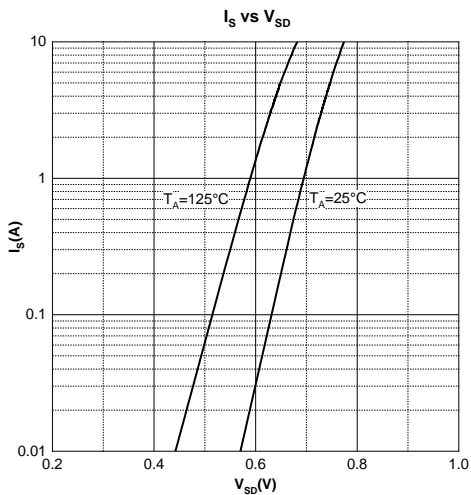
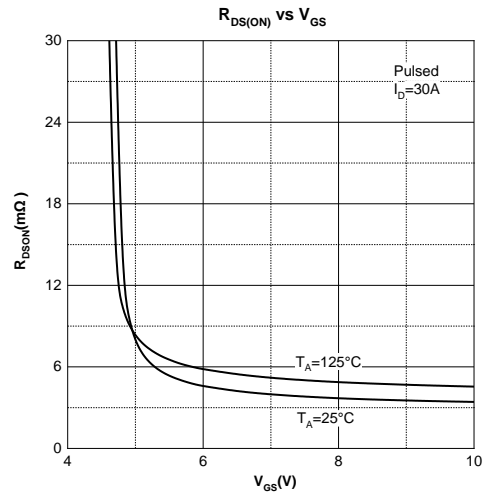
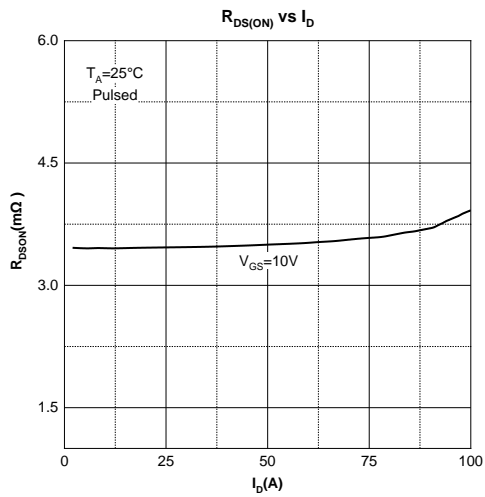
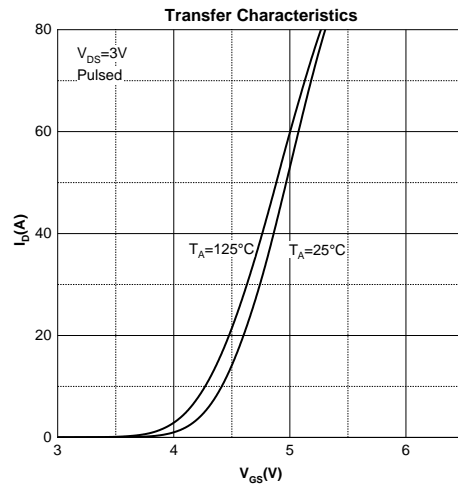
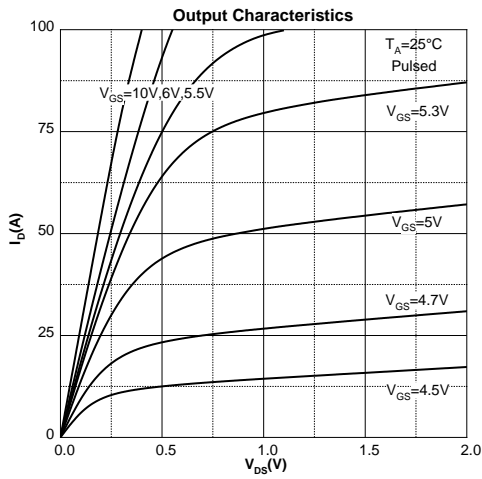

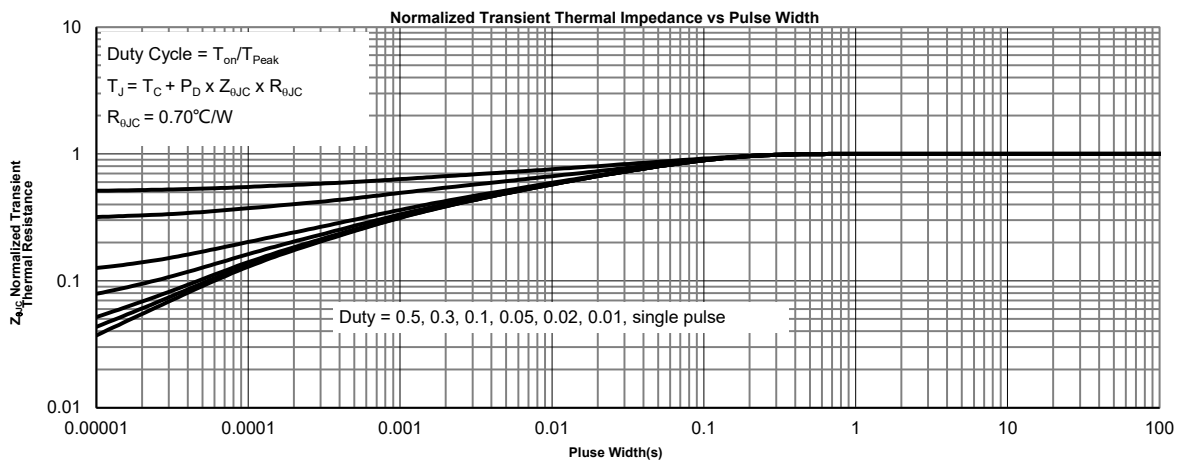
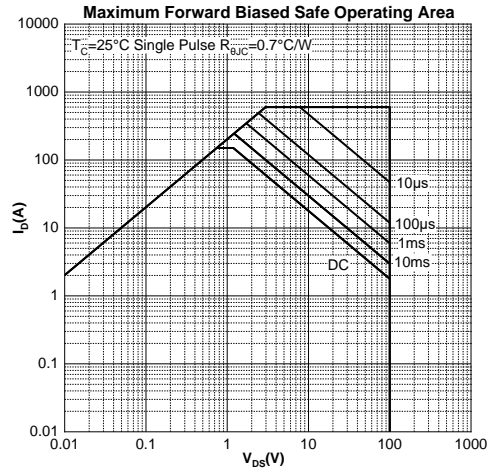
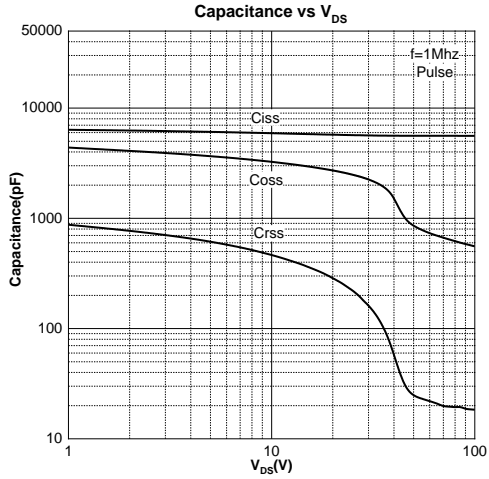

Gate Charge Test Circuit & Waveform

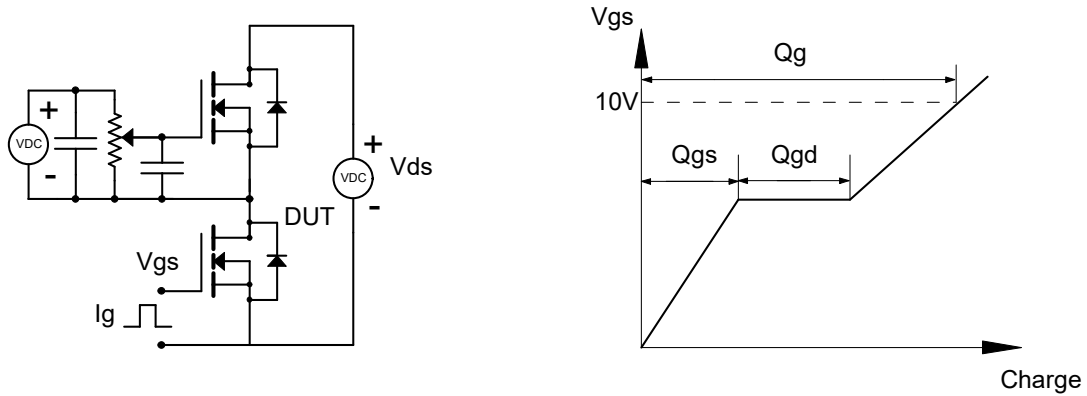

Resistive Switching Test Circuit & Waveform

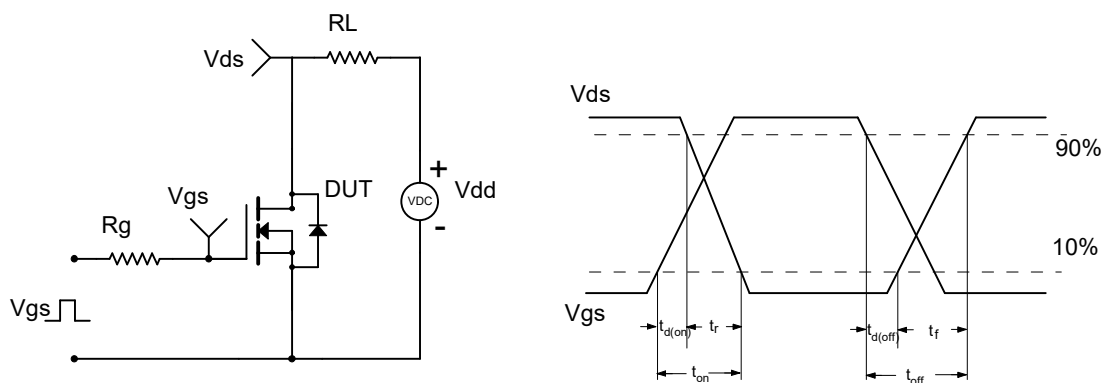

Unclamped Inductive Switching (UIS) Test Circuit & Waveforms

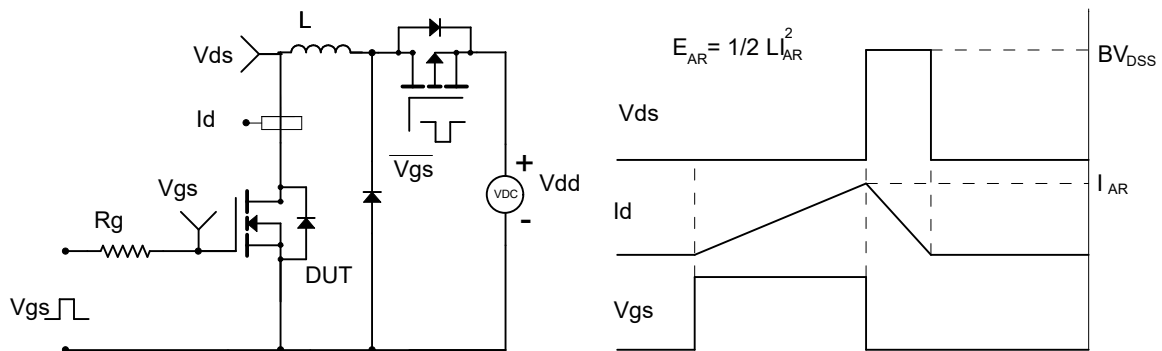

PDFN5X6-8L Package Information

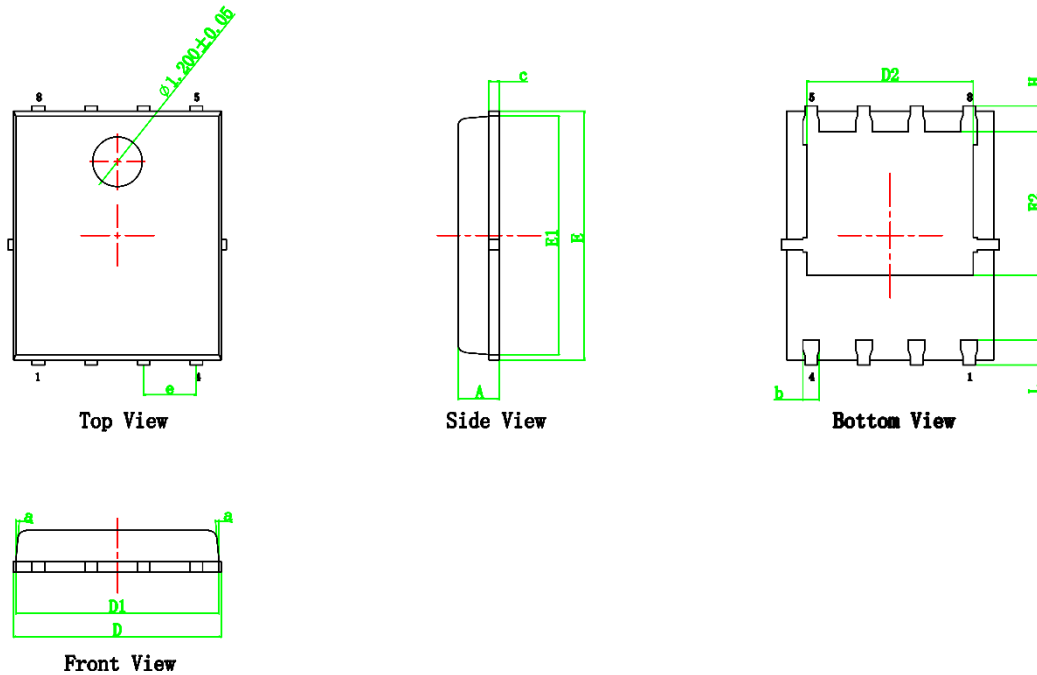

Symbol	Dimensions In Millimeters		Dimensions In Inches	
	Min.	Max.	Min.	Max.
A	0.900	1.200	0.035	0.047
b	0.330	0.510	0.013	0.020
c	0.190	0.300	0.007	0.012
D	4.800	5.220	0.189	0.210
D2	3.900	4.300	0.154	0.170
E	5.900	6.100	0.232	0.240
E1	5.700	5.800	0.224	0.228
E2	3.350	3.750	0.132	0.148
e	1.270REF		0.050REF	
H	0.350	0.720	0.014	0.028
D1	4.800	5.000	0.189	0.197
L	0.350	0.750	0.014	0.030
a	0°	12°	0°	12°

Attention:

- GreenPower Electronics reserves the right to improve product design function and reliability without notice.
- Any and all semiconductor products have certain probability to fail or malfunction, which may result in personal injury, death or property damage. Customer are solely responsible for providing adequate safe measures when design their systems.
- GreenPower Electronics products belong to consumer electronics or other civilian electronic products.